

Reducing freight wagon noise at the source

Freight wagons remain the source of high levels of noise despite European legislation prohibiting the use of cast-iron brake blocks on new wagons. **Dr Martin Toward, Dr Giacomo Squicciarini, and Professor David Thompson** from the University of Southampton's Institute of Sound and Vibration Research look at current efforts to mitigate rolling noise and curve squeal from freight rolling stock.

RAILWAY noise is often a major source of annoyance for people living close to railways and can be a major issue when authorities seek public support to build new or increase the capacity of existing lines.

Often the dominant source is rolling noise, generated by the surface unevenness (roughness) at the rail/wheel interface which is radiated by the sleepers, rails and wheels. Wheel roughness is highly dependent on the type of brakes fitted. In continental Europe, cast-iron tread brakes are still widely used on freight wagons, with the

abrasive actions of a cast-iron brake block on the wheel tread resulting in high levels of wheel roughness which, at most wavelengths, dominate over the rail roughness. The result is high noise levels compared with passenger trains, which are generally fitted with composite tread brakes or disc brakes. Moreover, freight trains often operate at night when the potential for disturbance is highest.

All new freight wagons in Europe must now be fitted with composite brakes (K or LL types), which result in much lower levels of wheel roughness and noise, to comply with noise limits introduced in 2006. However, the slow renewal rate of wagons due to their long lifespan means that the vast

majority are still fitted with cast-iron blocks. Indeed, it was estimated that only 37,000 of Europe's 411,000-strong freight wagon fleet were fitted with composite brakes in 2012.

The introduction of composite LL type blocks, which have similar friction characteristics to cast-iron blocks and can be retrofitted to existing wagons, typically results in a noise reduction of around 7 to 10 dB(A), or roughly half the perceived loudness.

wagons including by increasing financial support, and introducing mandatory noise limits and noise-dependent track access charges.

Germany subsequently introduced a system where 'noisy' trains are required to pay a track access surcharge from which retrofitted 'quiet' wagons are exempt. In addition 'quiet' wagons also receive a mileage-based bonus. Switzerland has gone a step further by passing a federal law banning wagons fitted with cast-iron brake blocks from 2020. Indeed it now seems inevitable that

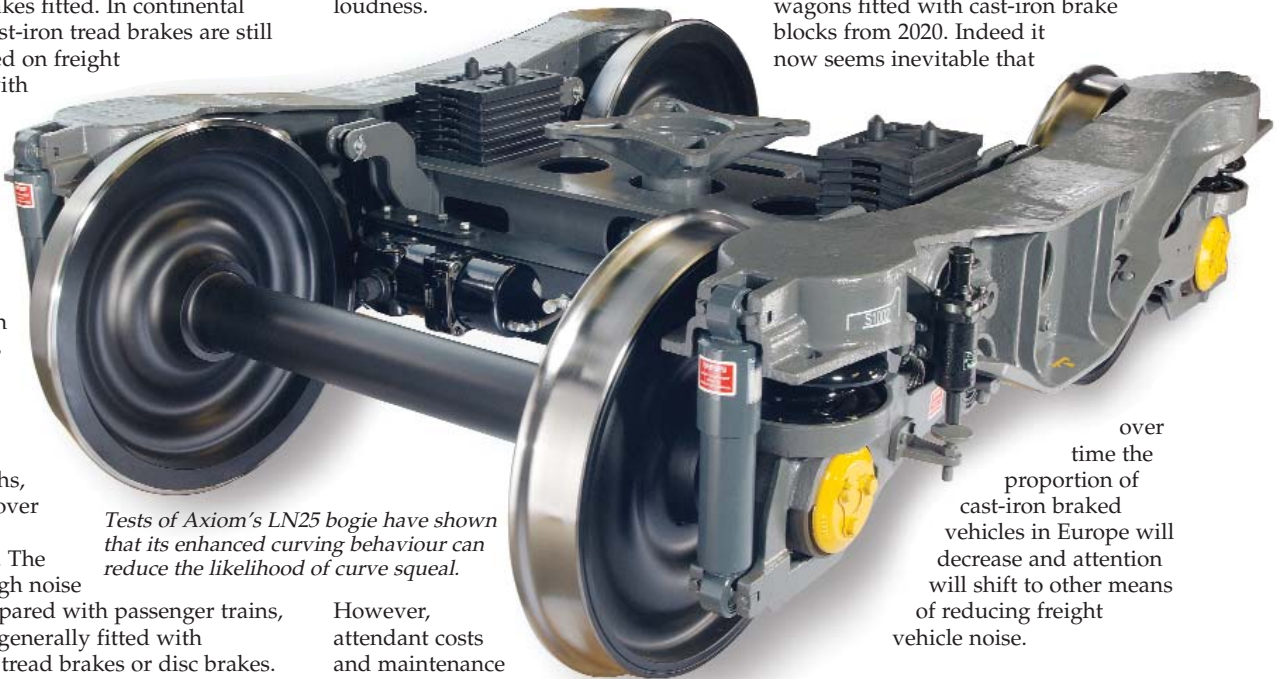

Tests of Axiom's LN25 bogie have shown that its enhanced curving behaviour can reduce the likelihood of curve squeal.

However, attendant costs and maintenance considerations have meant there has been little incentive for operators to retrofit wagons with composite blocks until recently.

Recognising this issue, the European Commission published a Roadmap for the reduction of noise generated by freight wagons in April 2013. The Roadmap considers options to increase retrofitting composite brakes to existing

over time the proportion of cast-iron braked vehicles in Europe will decrease and attention will shift to other means of reducing freight vehicle noise.

Wheel design

At low frequencies (<1000Hz) rolling noise is mainly radiated by vibration of the track. However, at higher frequencies wheel noise becomes increasingly important. This is particularly the case in continental Europe where relatively stiff rail pads limit the rail contribution.

Railway wheels are very lightly

Noise and vibration

damped so the noise they radiate is heavily influenced by their resonant behaviour. Coupled with an axisymmetric nature and single connection point at the axles, this means that they resonate with negligible motion at the wheel centre.

As a result the vibration behaviour of the wheel is largely unaffected by the rest of the train and consequently noise control measures focus predominately on reducing excitation (ie the roughness) or the vibration and radiation of the wheel. Noise from the bogie or vehicle body is usually negligible in comparison unless the suspension is in poor condition.

Design can influence noise radiated by the wheel. To illustrate this, we carried out noise predictions for two different freight wheel designs. The first is the BA319 wheel used on the European standard Y25 bogie, which is fitted with either composite or cast-iron blocks, while the second is the wheel fitted to the Axiom Rail LN25 bogie, which is fitted as standard with composite blocks.

The Twins model used in the predictions calculates the noise radiated

Table 1

	Wheel dB(A)	Track dB(A)	Total noise dB(A)
Cast-iron braked BA319 wheel	87.5	88.9	91.3
Composite braked BA319 wheel	80.3	81.4	83.9
Composite braked LN25 wheel	78.4	80.7	82.8

Twins predictions showing the contributions of wheel and track components to total noise for the BA319 wheel and the LN25 wheel.

by the rails, wheels and sleepers from parameters relating to the track and vehicles. Here we have assumed some typical track and train characteristics for freight in Europe: UIC-60 rail, concrete monoblock sleepers, stiff rail pads, and 120km/h train speeds.

The wheels are modelled using finite elements from which mode shapes and natural frequencies are extracted and damping values assigned; the designs are illustrated in Figure 1.

These clearly show the LN25 wheel has a thicker web with less curvature while its diameter is 80mm less than the

industry standard BA319 wheel. As a consequence, assuming roughness corresponding to composite brake blocks for both wheels, the LN25 wheel is predicted to radiate around 2 dB(A) less noise than the BA319 wheel, while the combined noise level from wheel and track is predicted to be around 1 dB(A) lower (see Table 1).

As expected the total noise level with the cast-iron braked BA319 wheel is significantly higher than either wheel utilising composite brakes (8.5 dB(A) and 7.4 dB(A) respectively). In all cases, the wheel makes slightly less noise than the track.

There is little evidence to suggest that fitting wheels with disc-brakes to freight wagons offers any significant benefits in terms of roughness compared with composite blocks. However, they can offer some secondary benefits in terms of wheel design.

Whereas tread-braked wheels are required to have a curved web to allow for thermal expansion under braking, this is not required for disc-braked wheels. This means straight (and thick) webs and wheels may be of a smaller diameter, both of which are beneficial for noise reduction.

A further benefit of using disc brakes is that the wheel-mounted discs increase wheel damping, reducing the magnitude of its resonances. Commercially available wheel dampers are now available to exploit the same effect. Designs of these vary considerably and include mass-spring dampers, interlocking plates and friction rings that are inset into the wheel. A round-robin test of wheel dampers in the European Stardamp project found that the efficacy also varied considerably but that reductions of up to 9 dB(A) in the wheel component and up to 2.5 dB(A) in the total noise are possible.

Curve squeal

Curve squeal noise is another major source of annoyance to the railways' neighbours, and it can often be much more acute than rolling noise due to its high magnitude and tonal nature. In most cases wheel squeal is initiated at the interface between the wheel tread and the rail. Squeal occurs because train axles are not able to steer perfectly around a corner, which results in lateral creepage at this interface, particularly for the front inner wheel of a bogie or vehicle. Stick-slip behaviour then excites the wheel at

Figure 1

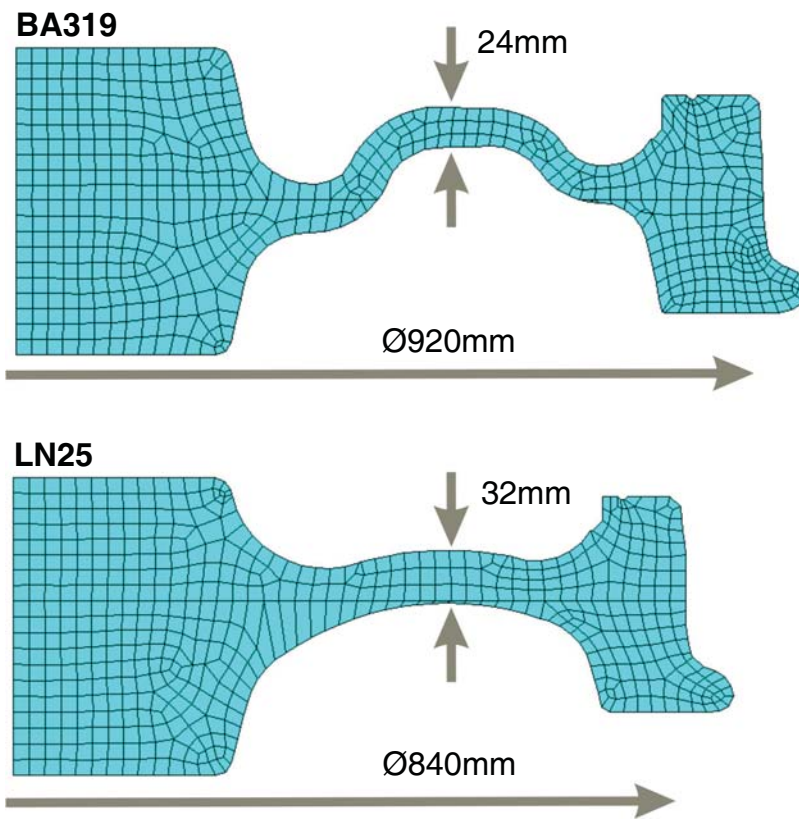

Finite element models of the cross-sections of the BA319 and LN25 wheels.

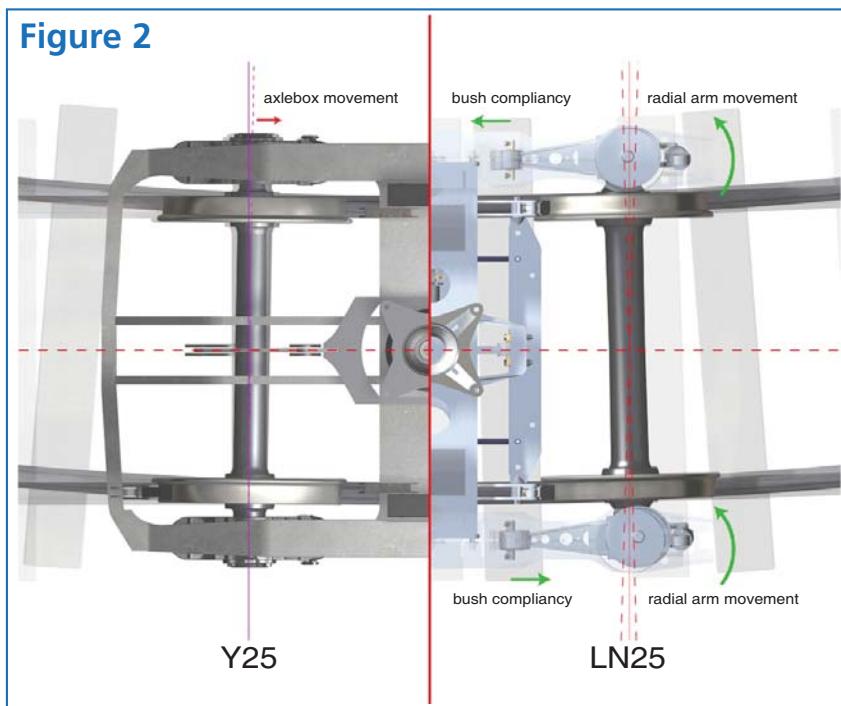

Comparison of steering mechanisms of industry standard Y25 bogie and the Axiom Rail LN25 bogie.

one or more of its natural frequencies resulting in the radiation of noise from the wheel.

Due to the very high magnitude of curve squeal, solutions generally aim to eliminate the squeal rather than reduce its severity. While lubricating the wheel/rail interface is undesirable with respect to adhesion, friction modifiers are available which aim to interrupt the stick-slip behaviour without significant loss of adhesion. Systems that deploy these are often located on the track but vehicle-mounted systems are also available.

For the vehicle, an important design consideration with respect to squeal is

the yaw angle of the front wheelset relative to the rail. One way to reduce this is to minimise the distance between the axles (a simple rule of thumb being that squeal is likely to occur when the curve radius is less than 100 times the wheelbase). However, the scope for this on freight bogies is limited; the Y25 bogie has a wheelbase of 1.8m and other design constraints will limit any further reductions.

Alternative

An alternative method to minimise the yaw angle uses suspensions which enable the axles to steer and reduce

creepages during curving. The LN25 bogie has a radial arm design suspension which allows greater yaw angles than the industry standard Y25 bogie (Figure 2).

Recently, we investigated the effect of this increased steerability on the likelihood of squeal occurrence. Initially, both bogie designs were modelled using the vehicle dynamics software, Vampire, for various cases of curve radii, cant deficiencies and wagon loads. The creepages, contact point location and normal forces predicted in Vampire were then used as inputs for a curve squeal model we have developed.

From the results of these simulations, it is possible to estimate the statistical likelihood of squeal occurring for each case. Figure 3 compares the likelihood of curve squeal between the two bogies for different curve radii and shows that in severe cases (ie low curve radii) both bogies are likely to squeal. However, squeal continues for greater radii for the Y25 bogie than for the LN25 bogie. This trend was seen for all cant deficiencies, showing that the improved curving behaviour of the steerable LN25 bogie results in lower creepage values, which in turn can reduce the likelihood of curve squeal.

In summary, while at present the primary focus in Europe is rightly on reducing the number of 'noisy' wagons with cast-iron brake blocks, it is expected that over time attention will shift towards other means of noise reduction for freight wagons. Recent work has shown that there is significant scope in the design and damping of wheels to reduce rolling noise, and that by enabling the axles of freight bogies to steer, it is possible to reduce the likelihood of curve squeal. **IRJ**

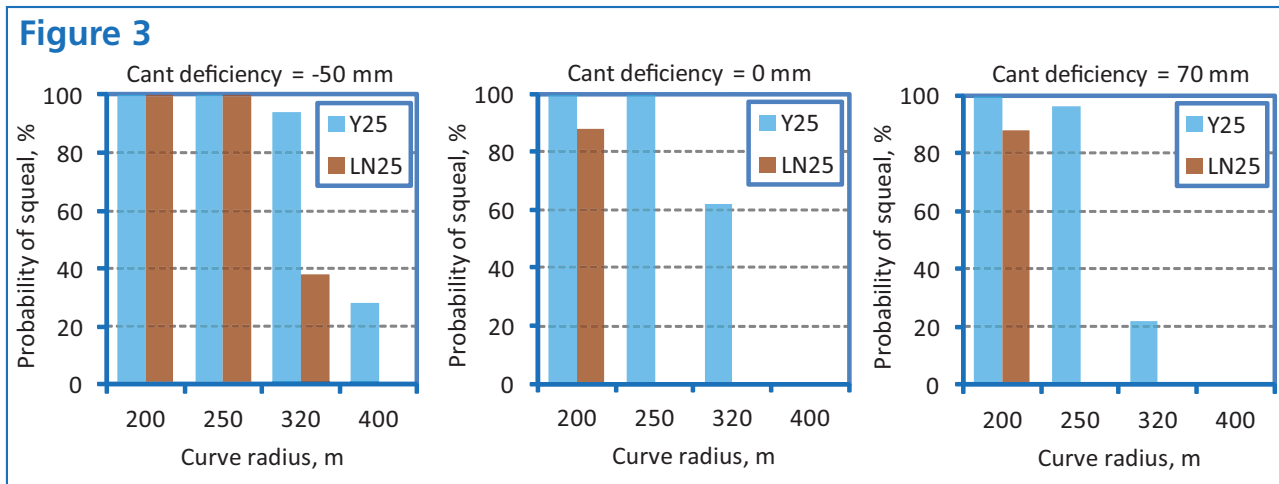

Comparison of curve squeal probability for the laded Y25 and LN25 bogies. In both cases the results are with the BA319 wheel.