

OBTAINING INPUT TERMS FOR RAILWAY NOISE FOR USE IN STRATEGIC NOISE MODELS

DEJ Lurcock ISVR Consulting, University of Southampton, UK
MGR Toward ISVR Consulting, University of Southampton, UK
DJ Thompson ISVR, University of Southampton, UK

1 INTRODUCTION

In the UK, as elsewhere, railway noise mapping is becoming increasingly used to predict and characterise noise from the railway networks, and on a strategic level is mandated by law. However, since railway noise is highly dependent on train speed, rolling stock factors, track construction and maintenance, obtaining appropriate source terms for these models is not straightforward.

One of the aspects of difficulty is the provision of terms for individual sources of railway noise, which include wheel/rail (including rolling noise, impacts and 'squeal'), aerodynamic, traction and equipment sources. The topic of separating and quantifying these noise sources using measurements is the subject of European and International research projects (e.g. TRANSIT¹ and UIC Aeronoise²). In addition, a CEN working group is currently working on producing a Standard for determining railway noise source terms, which is in draft for consultation³.

2 RAILWAY NOISE SOURCES

To highlight the complexities around specifying noise source terms for railways, it is helpful to understand the mechanisms behind the dominant sources of noise. A comprehensive guide to railway noise sources is included in Thompson's book⁴.

2.1 Rolling noise

At the majority of operating speeds on the UK rail network, the most significant noise contributor is from rolling noise. Due to small imperfections on the wheel and rail surfaces (i.e. 'roughness'), dynamic interaction forces are exerted on the wheels and rails, which vibrate and radiate sound to the environment (see Figure 1).

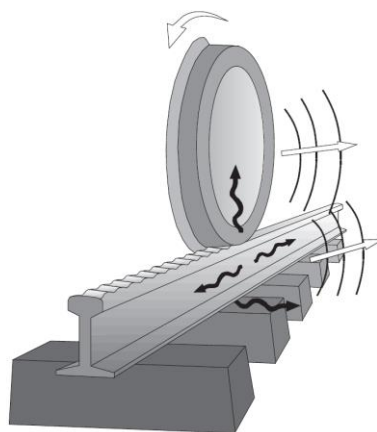

Figure 1. Mechanisms of rolling noise generation, from ⁴

For the wheel, the radiated sound is dependent on its modal characteristics. In most situations, the wheels are the dominant source of rolling noise above about 2 kHz.

At lower frequencies, the track components form the dominant source. This has a strong dependence on the 'track decay rate', which is a measure of how quickly (with distance) vibration decays along a track⁵. If soft railpads are used, then the rail vibration can propagate further and the noise from the rail is higher. The railpads also affect the amount of vibration transmitted to the sleepers, which become the dominant source of rolling noise at low frequencies. There are also differences between the noise radiation from slab track and conventional ballasted track⁶.

Various mitigation options exist for rolling noise, including damping treatments applied to the wheel and rail, shrouds around the bogies, and low-height barriers, but such options are expensive, and not routinely applied. The radiated sound pressure is directly proportional to the combined surface roughness of the wheel and rail; therefore ensuring smooth rail and wheel surfaces is an important aspect in track and rolling stock maintenance. Impact noise occurs due to discrete discontinuities, for example at rail joints, switches and crossings as well as due to wheel flats. Track discontinuities increase the noise in their specific locality and often cannot be avoided. Wheel flats occur due to wheel slide and should normally be removed by reprofiling; they are therefore not included in prediction schemes.

It is commonly accepted that the overall A-weighted rolling noise level increases with train speed V according to a $30\log_{10}(V)$ relation. However, the roughness spectrum is a function of wavelength, and therefore shifts upwards in frequency as the speed increases. This means that the true speed dependency is more nuanced than a simple overall correction suggests.

The radiated sound is often increased, for example, in the presence of bridges or viaducts. In these instances, the direct sound from the wheels and track may be shielded by parapets, but vibration from the track is transmitted to the structure, which in turn radiates sound. Strategic noise map protocols provide the facility to apply a bridge correction, although in reality there are large differences between the acoustic behaviour of different bridges. It would be unfeasible to obtain accurate corrections for every bridge on a rail network.

Finally, wheel/rail noise also includes 'squeal' on sharply curved track. This can be exceedingly difficult to predict, and is dependent on wheel and track parameters, train speed, loading and even meteorological effects.

2.2 Traction/equipment noise

At standstill or low speeds, the dominant noise sources are from traction and other on-board equipment. In terms of traction equipment, sources can include diesel engines in locomotives or diesel multiple units, gearboxes, electric motors and their associated cooling fans. Other equipment can include transformers, power converters, compressors, pumps, fans and HVAC systems. Source sound power levels might be known for some equipment, but accessing a full set of source information is difficult. Moreover, some are known in free-field conditions but require account to be taken of installation effects (e.g. shielding by the train body, fairings, louvres etc).

2.3 Aerodynamic noise

Whilst the UK currently has limited high-speed rail (only HS1, with phase 1 of HS2 under construction), it should be noted that at high speeds (above around 300 km/h), aerodynamic sources become dominant.

Aerodynamic noise is caused principally by turbulence, vortex shedding and cavity resonance effects. High-speed trains exhibit a turbulent boundary layer over the whole surface. Components such as pantographs, pantograph recesses, bogies, inter-coach gaps, windscreen wipers and even jacking points are sources of aerodynamic noise (see Figure 2). Each has its own blend of aerodynamic mechanisms, and resulting sound power spectra, directivities and speed dependence. In general, the overall speed dependence of aerodynamic noise is often taken as having a $60\log_{10}(V)$ characteristic, but in reality this varies with frequency and among individual sources.

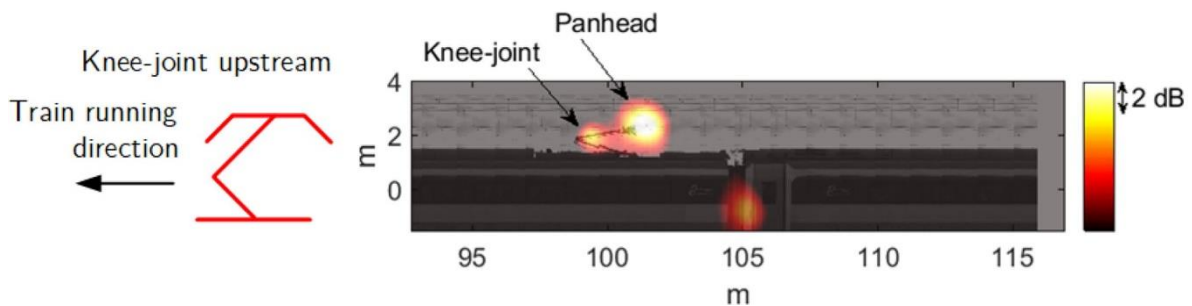

Figure 2. Aerodynamic noise sources on a train at 273 km/h, 400-4000 Hz, from ⁷

2.4 Other sources

Further situation-specific noise sources are not commonly considered in strategic noise assessments, but can include train-mounted warning horns, platform announcements, and noise from maintenance activities.

3 NOISE MAPPING PROTOCOLS

Strategic noise mapping has become a necessary tool to identify noise hotspots, and inform decisions made on a strategic level. The Environmental Noise Directive (END)⁸ which was transposed into UK law as the Environmental Noise (England) Regulations 2006, requires strategic noise maps to be developed (including rail and major roads) and published for all major routes and agglomerations. The noise indicators L_{den} and L_{night} are used. This section details some of the underlying calculation protocols that are used.

3.1 Calculation of Railway Noise 1995 (CRN)

Published in 1995, The Calculation of Railway Noise (CRN)⁹ has been a commonly used basis for calculating noise from railways in the UK. It provides a framework to determine overall A-weighted noise levels (in the form of L_{Aeq}) from railways, and includes a selection of data for UK-specific rolling stock. Its original purpose was to be used as a basis for assessing eligibility for sound insulation under the Noise Insulation (Railways and Other Guided Transport Systems) Regulations 1996¹⁰, not explicitly as a basis for large scale strategic noise mapping.

The database of available vehicle terms was relatively limited and has not been extensively updated to reflect modern rolling stock, although some additional terms were provided in 2007¹¹, and guidance is provided on obtaining new terms for other rolling stock through measurement.

When calculating the acoustic propagation, most sources are considered to originate from the location of the rail head, with the exception of diesel locomotives under power, for which the source is assumed to be located 4 m above the closest rail.

The standard procedures assume 'good condition' ballasted track with continuously welded rail. Whilst some overall correction terms are provided for specific alternative track types, there is no straightforward provision for new track types or roughness levels, other than through measuring entirely new source terms for the alternative track, after it has been built.

3.2 HARMONOISE / IMAGINE

HARMONOISE¹² was an EU project (with an end date of 2005) to develop improved methods for prediction of road and rail noise, that could act as a comprehensive model to be used by all EU member states in their strategic noise maps. For railways, this included provision for source terms at 0.0, 0.5, 2.0, 3.0 and 4.0 m above the rail head (see Figure 3), with predictions in terms of 1/3 octave bands. It included the application of separate vehicle and track transfer functions.

The HARMONOISE model was extended in the EU IMAGINE¹³ project to include aircraft and industrial sources, to improve the categorization and management of noise emission databases, and to provide additional default data for common EU rail sources.

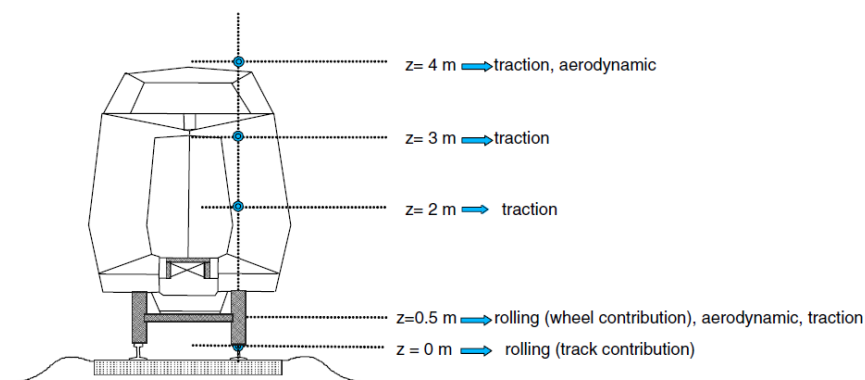

Figure 3. Source heights in HARMONOISE / IMAGINE model, from ¹⁴

3.3 DUTCH RMR

The Dutch RMR¹⁵ method (latest version published in 2012) offers some improvements over CRN, e.g. predictions can be obtained in terms of 1/1 octaves. An increased number of source heights is accommodated, with a total of five available: 0.0, 0.5, 2.0, 4.0 and 5.0 m above the rail head, and a protocol was established to distribute various source types for predefined rolling stock (specific to the Netherlands) between the various heights. Rolling noise is specified from terms that included wheel and rail roughness spectra (in 1/3 octave bands) and combined vehicle/track transfer functions, and additional overall speed correction factors were supplied for specific train types. Predefined corrections for track superstructure were also supplied in terms of 1/1 octave bands.

The supplied database of emission values was limited to Netherlands-specific rolling stock, making direct application to the UK difficult without new vehicle source terms. Some guidance was provided in RMR for obtaining new rolling stock terms, but this is rather complicated, and therefore a UK-equivalent dataset is not readily available.

3.4 CNOSSOS-EU

CNOSSOS-EU¹⁶ was developed by the European Commission between 2009-2012, in response to differences between EU member states' approaches, which made direct comparisons of strategic noise maps difficult. For railway noise, the revised model took inspiration from the HARMONOISE / IMAGINE approach, but with some simplifications to increase computational speed, and perhaps to

improve the likelihood of adoption by EU member states. It again used 1/3 octave bands. There were also refinements to the categorisation of source data in the database specification. The number of source heights was reduced to two, 0.5 m and 4.0 m (see Figure 4), but the HARMONOISE / IMAGINE approach of accommodating specific vehicle and track transfer functions was maintained.

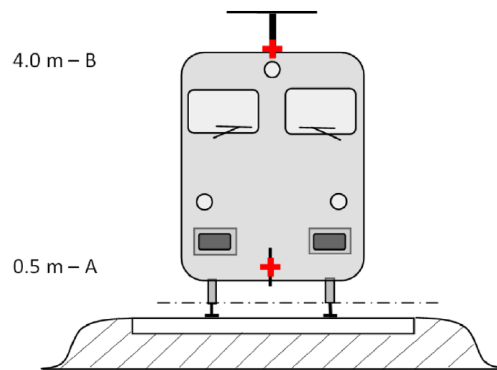

Figure 4. Source heights in CNOSSOS-EU model, from ¹⁶

4 CHALLENGES

Despite its limitations, CRN is still used as the assessment basis for new strategic noise maps in the UK, although it is assumed that the CNOSSOS-EU prediction model (or a derivative) will be the most common choice of railway noise model in the future. RMR is currently adopted in Ireland. Whilst CNOSSOS-EU provides some default data, this does not cover a large proportion of UK rolling stock or track infrastructure, and therefore new source terms are required, including track and vehicle transfer functions, wheel and rail roughness spectra, traction source power levels, and for high-speed situations, appropriate aerodynamic noise source terms (and speed corrections).

4.1 Rolling noise

For rolling noise on modern (i.e. disc braked) trains, the most important parameter is the rail roughness. This can vary considerably by location, causing variations of up to 20 dBA in rolling noise emissions. Another important parameter for the track transfer function is the track decay rate, which is strongly affected by railpad stiffness. The railpads installed also vary across the UK network, and without a direct site-specific inspection or test, it is not currently possible to know which railpads are installed at any particular location.

4.2 Traction/equipment noise

CNOSSOS-EU requires input data on traction and equipment noise at specific characteristic speeds, but does not give advice on interpolation between speeds for railway sources. Establishing appropriate sound power terms for these sources presents challenges in terms of measurement of sound power levels, directivity, as well as speed dependency. In addition, in cases where manufacturers of specific items can supply adequate sound power data, the installation of these items on a train affects the radiated sound power level and directivity, which should be taken into account; acquiring this detailed information in 1/3 octave bands would usually require prohibitively expensive acoustic surveys.

4.3 Aerodynamic noise

Establishing source terms for aerodynamic sources has its own unique challenges. Such sources can be difficult to characterize adequately in laboratory tests, due to the costs involved for full-size test setups that simulate the intended train installation.

Steps have been made in quantifying such sources based on train pass-by measurements, for example using microphone arrays and beamforming techniques (e.g. see Figure 2 above). In addition, the UIC Aeronoise² project aims to provide a relatively simple method to quantify noise from aerodynamic sources. Both approaches face challenges when separating aerodynamic sources from other sources, especially bogie aerodynamic noise from rolling noise. Moreover, they require certain assumptions to be made about source location and/or directivities, which may not be appropriate when extending predictions to other receiver positions.

4.4 Line source approximation

Since trains are moving objects, it is natural that when included in large scale noise mapping, sources should be transposed to equivalent line sources. CNOSSOS-EU provides no guidance on how to achieve this, other than specifying that mid-height sources should be attributed proportionately to the 0.5 and 4 m sources. Whereas for simple monopole sources under free-field conditions, this could be obtained relatively simply, when including the effects of source directivity, ground reflections and Doppler shift, this process becomes much more complicated, and requires a time-stepping approach that not all practitioners would have access to.

5 SOLUTIONS

As both researchers and consultants, the authors have been involved in several recent projects that have required updated source terms for noise mapping in the British Isles. These have included projects for DEFRA (UK-wide noise mapping), HS2, and Luas (Dublin tram operators). The approach taken for these has varied according to differences in relevant sources, operating conditions/speeds and target noise map model.

5.1 Line source approximation

To characterise relevant railway noise sources as line sources, use is made of the commercially available software 'Train Noise Expert'¹⁷. Using procedures originally developed in the EU project ACOUTRAIN¹⁸, this software allows railway sources (point, line, area or volume sources) to be specified at their appropriate locations on a train, and pass-by sound pressure levels to be calculated at any receiver point (see Figure 5). Train Noise Expert processes the acoustic emission in time-steps, and can therefore account for source directivities, Doppler shift and ground reflections for each source as the train passes.

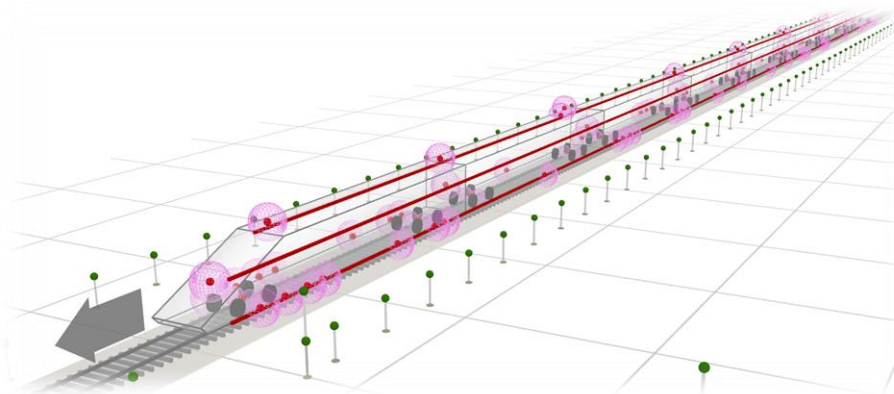

Figure 5. Sources and receivers defined for a train model in Train Noise Expert

By including reference line sources representing the full train length in the calculations (at the correct heights, dependent on target noise mapping protocol), resultant sound pressure levels at a reference receiver location (e.g. 7.5 m from the centre of the track) can be compared with the results of the train pass-by, and it is then possible to determine the equivalent line source sound power per metre that corresponds to the particular source being evaluated.

5.2 Rolling noise

For CNOSSOS-EU the rolling noise component must be separated into track and vehicle transfer functions, wheel and rail roughness and contact filter (see Figure 6). This framework is based originally on the TWINS model¹⁹.

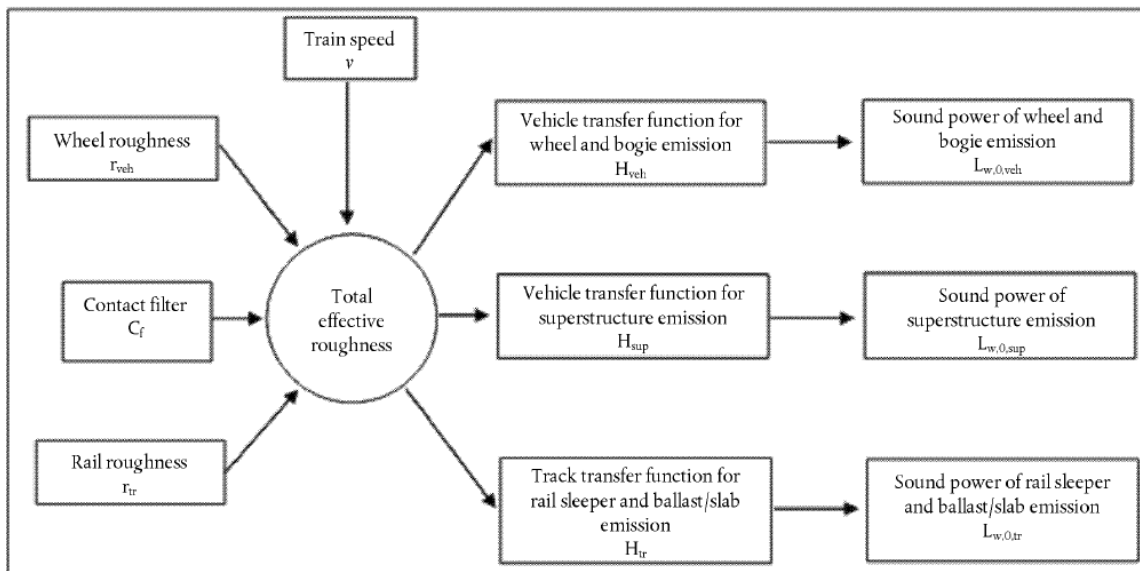

Figure 6. Rolling noise model implemented in CNOSSOS-EU (and HARMONOISE/IMAGINE), from ¹⁶

Roughness spectra and contact filter are specified as functions of wavelength and are combined in the CNOSSOS-EU calculation to form the ‘total effective roughness’, which is converted into a function of frequency according to the train speed. N.B. this conversion inevitably results in frequency bands that do not match the ‘preferred’ frequency bands required by environmental noise

calculations, and therefore some kind of interpolation of values is required in the calculation procedure.

Roughness monitoring has been undertaken on several types of UK track using a corrugation analysis trolley (CAT), from which a database of representative values has been generated. However, in the absence of site-specific data, it is recommended that the default values in CNOSSOS-EU be used.

The wheel roughness is usually a secondary consideration for most modern rolling stock (i.e. with disc braked wheels, which are significantly smoother than historical tread-braked wheels). A round-robin study of wheel roughness has provided statistical information on the roughness of various wheel types²⁰ from which the average roughness for disc-braked stock can be used.

The contact filter attenuates the excitation by roughness wavelengths that are short in comparison with the contact patch between the wheel and the rail. This can be established for certain wheel sizes and normal loads using Remington's formulation²¹, according to the rolling stock likely to be present in the target noise model.

The track transfer function gives the sound power radiated by the track components, namely the rails and the sleepers, due to a 'unit' roughness. In Train Noise Expert, a validated rolling noise prediction model is used, which is based on the TWINS approach¹⁹, to predict the sound power from the rail and sleepers for a single wheelset; CNOSSOS-EU makes corrections for the number of wheelsets on the train.

Similarly, Train Noise Expert (utilising the TWINS-based approach) can be used to predict the sound power from the wheels for a unit roughness (for a single wheelset), to form the vehicle transfer function. The model accounts for the different modal characteristics of a wheel (see Figure 7), and therefore these calculations require detailed finite element models and/or measured results of the wheel response. Modelling the acoustic response of rolling stock wheels requires specialist knowledge and is time consuming. To date, therefore, only limited vehicle transfer functions have been calculated for specific UK rolling stock. Consequently, unless detailed information is available, it is recommended to use the default CNOSSOS-EU vehicle transfer functions.

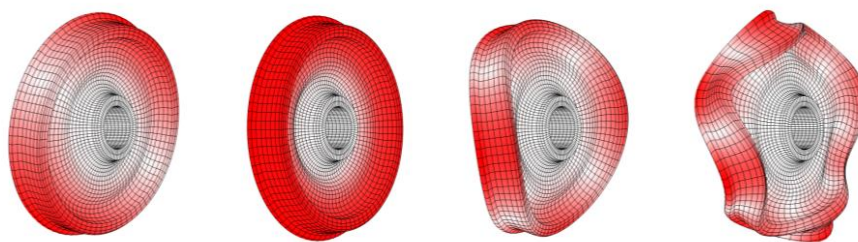

Figure 7. Example modes for a generic wheel, 214, 296, 412 and 1945 Hz, respectively.

Where separate vehicle/track transfer functions are not required (e.g. for RMR noise models), rolling noise terms have been established by undertaking trackside sound pressure level measurements alongside wheel and rail roughness measurements. By approximating the rolling noise with an equivalent continuous line source and normalising to the measured roughness level, RMR emission terms can be obtained for specific vehicle/track combinations.

5.3 Traction/equipment noise

For most railway speeds and operating conditions, rolling noise can be assumed to be the dominant noise source; for traction sources it is therefore recommended to use default CNOSSOS-EU terms for simplicity. Nevertheless, for some projects specific sound power levels of items already installed on trains are used, with spectra obtained from sound pressure level measurements on a train at

standstill. This relies on the assumption that the noise from these sources is independent of speed, which should be verified by more detailed investigation.

5.4 Aerodynamic noise

For high-speed trains there several sources of note. One of the most important is the pantograph. This is because of its elevated position on the train, which limits the effectiveness of conventional trackside noise barriers as a mitigation option. A combination of pass-by noise measurements (from which the contribution from the pantograph can often be clearly identified in specific time windows) on operational trains, beamforming experiments/analysis⁷ and empirical prediction models has been used to characterise the sound power and directivity of a specific pantograph.

A semi-empirical model has been developed at the University of Southampton which allows an aerodynamic noise source to be represented by a collection of cylinders of different sizes and angles to the flow (see Figure 8)²². For a given speed, the sound power and directivity of a composite source such as a pantograph can be obtained.

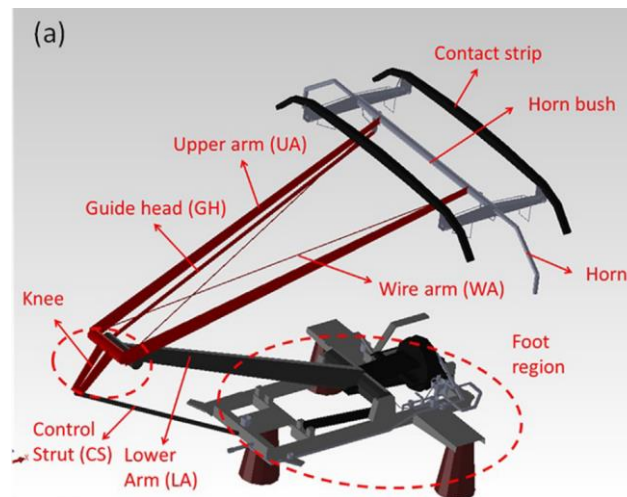

Figure 8. Pantograph components included in a component-based noise model, from ²²

For other aerodynamic sources, where the flow is not as well-defined (such as objects in the bogie region, intercoach gaps and the turbulent boundary layer) a combination of beamforming techniques and values from literature (e.g. sources listed in ⁴) have been used to obtain representative terms.

5.5 Future developments

Despite the challenges faced in obtaining suitable source terms, several current developments offer potential for further improvements. Output from the TRANSIT project includes improved methods for source separation and for assessing installation effects of equipment on trains. The UIC Aeronoise project promises an approach for determining aeroacoustic noise from trackside sound pressure measurements (with six microphones attached to the catenary mast). The CEN working group is also working to establish equivalent sound power level quantities from trackside sound pressure level measurements.

In parallel, work is underway with HS2 and noise mapping software developers to provide additional functionality in the Train Noise Expert prediction tool. This will enable the output of data from detailed train source models to formats that can be used in the CNOSSOS-EU, HARMONOISE/IMAGINE and RMR noise mapping protocols. This should be complete by the end of the year.

6 CONCLUSIONS

Strategic noise maps are required for all major rail networks in the UK. Whilst available noise models have advanced considerably in their level of detail over the last 20 years, there remain many challenges in obtaining suitable UK-specific source terms. These include determination of track and vehicle transfer functions, wheel and rail roughness values, and traction/equipment and aerodynamic source characterisation.

Advances are being made in the processes of characterising sources, with a CEN source term measurement working group, outputs from the TRANSIT project, and the UIC Aeronoise project, all of which are set to provide practitioners with additional guidance for railway terms.

Practical approaches for obtaining terms for CNOSSOS-EU and RMR have been briefly described, which have involved use of the Train Noise Expert software to calculate equivalent line source sound power levels, with individual source values obtained from combinations of measurement (e.g. wheel/rail roughness, track decay rate and pass-by sound pressure levels) and reference to literature.

7 REFERENCES

1. TRAIIn pass-by Noise Source characterization and separation Tools for cost-effective vehicle certification (TRANSIT) project. <https://transit-prj.eu>.
2. UIC Aeronoise project. <https://shop.uic.org/en/other-documents/14272-aeronoise-measurement-and-analysis-systems-to-characterise-the-aerodynamic-noise-of-high-speed-trains-technical-report-benchmark-studies.html> (2022).
3. *Railway applications - Acoustics - Measurement of source terms for environmental noise calculations prEN 17936, CEN/TC 256*. (2023).
4. Thompson, D. J. *Railway Noise and Vibration: Mechanisms, Modelling and Means of Control*. (Elsevier Ltd, 2009).
5. *EN 15461:2008+A1:2010 Railway applications – Noise emission – Characterization of the dynamic properties of track selections for pass by noise*. European Committee for Standardization (2010).
6. Zhang, X., Jeong, H., Thompson, D. & Squicciarini, G. The noise radiated by ballasted and slab tracks. *Applied Acoustics* **151**, (2019).
7. Liu, X. *et al.* Aerodynamic noise of high-speed train pantographs: Comparisons between field measurements and an updated component-based prediction model. *Applied Acoustics* **175**, (2021).
8. *Directive 2002/49/EC of the European Parliament and of the Council of 25 June 2002 relating to the assessment and management of environmental noise - Declaration by the Commission in the Conciliation Committee on the Directive relating to the assessment and management of environmental noise*. (2002).
9. Department of Transport. *Calculation of Railway Noise*. (1995).
10. *The Noise Insulation (Railways and Other Guided Transport Systems) Regulations 1996*. (1996).
11. AEAT. *Additional railway noise source terms for 'Calculation of Railway Noise 1995'*. (2007).
12. HARMONOISE: Harmonised, accurate and reliable prediction methods for the EU directive on the assessment and management of environmental noise. <https://cordis.europa.eu/project/id/IST-2000-28419> (2005).
13. IMAGINE: Improved Methods for the Assessment of the Generic Impact of Noise in the Environment. <https://cordis.europa.eu/project/id/503549> (2006).
14. Talotte, C. *et al.* Railway source models for integration in the new European noise prediction method proposed in Harmonoise. *J Sound Vib* **293**, (2006).
15. *Reken-en Meetvoorschrift Railverkeerslawaaï (RMR)*. De minister van Volkshuisvesting: Ruimtelijke Ordening en Milieubeheer (2012).

16. Kephelopoulos, S., Paviotti, M. & Anfosso-Lédée, F. *Common Noise Assessment Methods in Europe (CNOSSOS-EU)*. PUBLICATIONS OFFICE OF THE EUROPEAN UNION (2012).
17. Lurcock, D. E. J., Thompson, D. J. & Squicciarini, G. Train Noise Expert. <http://trainnoiseexpert.com>.
18. Thompson, D. & Squicciarini, G. *Basic global prediction tool and user manual (final update of D4.2), EU FP7 project ACOUTRAIN, grant agreement no. 284877, Deliverable D4.7*. (2014).
19. Thompson, D. J., Hemsworth, B. & Vincent, N. Experimental Validation of the TWINS Prediction Program for Rolling Noise - Part 1: Description of the Model and Method. *J Sound Vib* **193**, 123–135 (1996).
20. Squicciarini, G., Toward, M. G. R., Thompson, D. J. & Jones, C. J. C. Statistical description of wheel roughness. *Notes on Numerical Fluid Mechanics and Multidisciplinary Design* **126**, (2014).
21. Remington, P. J. Wheel/rail noise-Part IV: Rolling noise. *J Sound Vib* **46**, (1976).
22. Latorre Iglesias, E., Thompson, D. J. & Smith, M. G. Component-based model to predict aerodynamic noise from high-speed train pantographs. *J Sound Vib* **394**, (2017).