

## The Daniell Cell

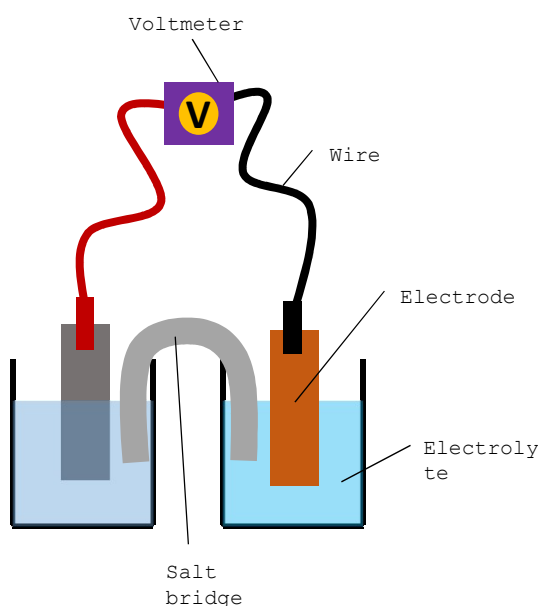

The Daniell Cell pictured, shows the two electrochemical reactions happening in different reaction vessels - we call these half cells.

On one side, zinc sits in zinc sulfate, and on the other copper is submerged in copper sulfate.

Both half cells are connected by the electrodes through a voltmeter, and also through the salt bridge which completes the circuit.

### What is happening?

We can work out which way the current flows using the reactivity series: we know already that zinc is more reactive than copper. This means that the following reactions are happening:

At the zinc electrode, zinc metal is being oxidised according to the following reaction:  $\text{Zn} \rightarrow \text{Zn}^{2+} + 2\text{e}^-$

At the copper electrode, copper ions from the electrolyte are being reduced to copper:  $\text{Cu}^{2+} + 2\text{e}^- \rightarrow \text{Cu}$

### Voltage calculation:

We can use the half cell equations and their